



DEVELOPMENTS IN GÉANT2: END-TO-END SERVICES

Roberto Sabatino - DANTE

3rd e-Concertation on e-Infrastructures
Helsinki 20 Nov 06

Agenda



Connect. Communicate. Collaborate

- GÉANT2 briefing and developments
- End to end services and the hybrid infrastructure
- Monitoring
- GÉANT2 activity JRA3 (BoD) introduction

GÉANT2



Connect. Communicate. Collaborate.

Some New Facts & Figures...

- 25 POPs (+4) serve >30 NRENs
- 11600 km of fibre + 140 ILA sites
- 50+ x (own) 10G lambdas
- 9 x (leased) 10G lambda
- 8 x 2.5G (leased) “lambda” + some lower speed links
- Juniper T640, M160, M40 routers
- NREN accesses at up to 10Gbps (+ backup) + P2P
- 4 x 10G to North America
- POP in NY
- connections to other R&E networks as before : Abilene, ESnet, CA*net4, SINET, TENET, RedCLARA, EUMEDCONNECT, TEIN2

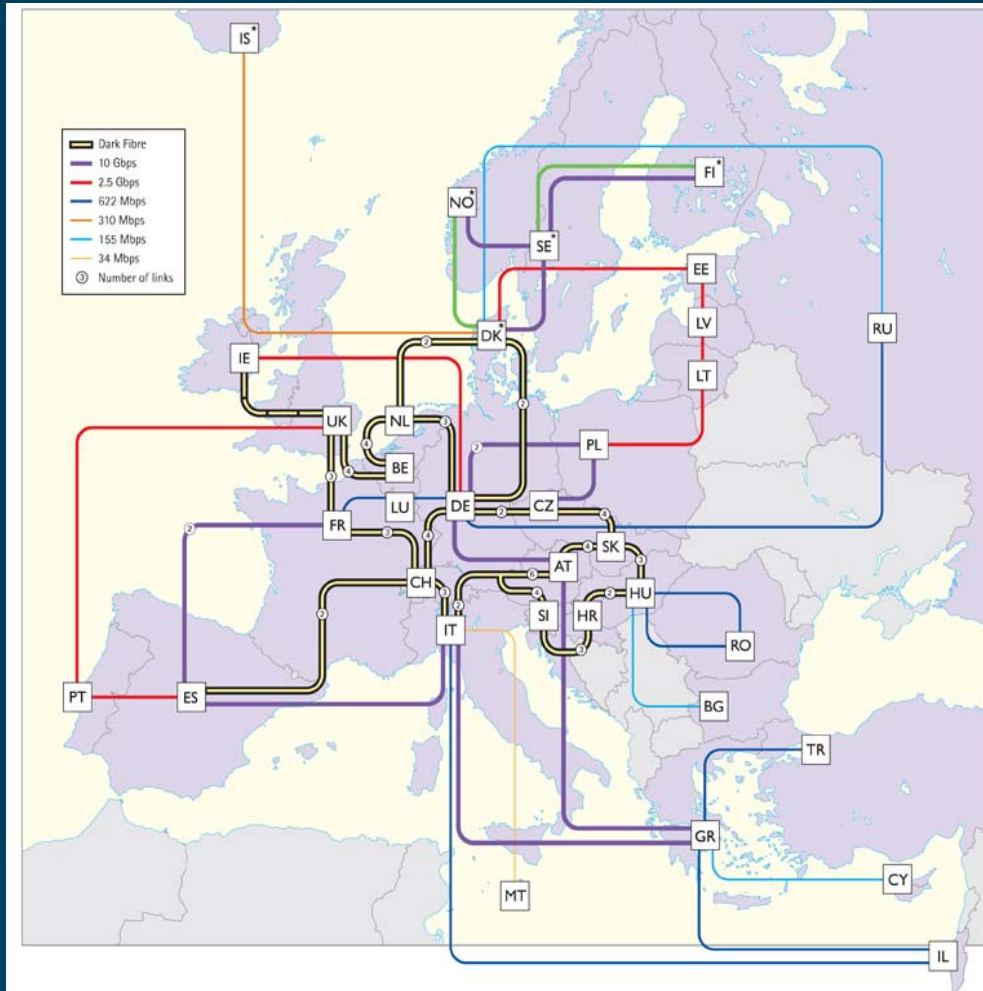

Provision of end-to-end (e2e) Services to e-Science



Connect. Communicate. Collaborate

- Up to now: Packet Switched IP (Layer 3) & MPLS Managed Bandwidth Services – VPNs
- From now on the **hybrid** NREN - GÉANT2 service model also enables:
 - Layer 2 Switched e2e circuits (e.g. 1 GigE) involving GÉANT2 facilities (+ local circuits provided by NRENs and Campuses)
 - 10 Gig Optical Private Networks (OPNs) configured for large e-Science projects using GÉANT2 DWDM & NREN - Campus *lightpaths*

and Service Joint Research/Activities



Connect. Communicate. Collaborate

JRA1 (perfSONAR) – Advanced Network Monitoring

- Versatile web services based framework for the measurement and exchange of network monitoring information (in collaboration with Internet2, see <http://www.perfsonar.net/>)
- Multidomain, IPv4 and IPv6
- On-demand and scheduled measurements
- MeasurementPoint (MP) and Measurement Archive (MA) services, presentation/analysis tools
- Started at L3 (IP), **now adding lower layers**

and Service Joint Research/Activities



Connect. Communicate. Collaborate

JRA3 – Bandwidth Allocation & Reservation

- Develop a connection-oriented, E2E, non-contended, guaranteed capacity P2P service (Ethernet, SONET/SDH, EoMPLS L2VPN)
- Multi-domain (hence multi-technology)
- With advance reservation
- Monitoring and security included in design leveraging other JRA's work
- More on this later...

Joint Research ~~Activities~~ and Service



Connect. Communicate. Collaborate

JRA4 – Technology & Service Testing

- Build distributed testbed for use by NRENs and other JRAs
- DWDM, SONET/SDH, Ethernet GFP
- Undertake technology testing programme of equipment and GMPLS
- Also dealing with [technical aspects surrounding use of so-called Cross-Border Fibre \(CBF\)](#)

Joint Research ~~and Service~~ Activities



Connect. Communicate. Collaborate

SA3 – End-to-end QoS (and more)

QoS (Premium IP)

- Make (IP packet) “quality” more ubiquitous
- Up to 4 classes of service
- Develop Premium IP provisioning system (AMPS) and (encourage) roll-out across many NREN domains

PERT: Develop and operate Performance Enhancement & Response Team

cNIS : Common Network Information Service containing topology information for all services

GIdP : GÉANT2 Identity Provider, central repository for certificates as a temporary solution based on Shibboleth

Agenda



Connect. Communicate. Collaborate

- GEANT2 status and developments
- End to end services and the hybrid infrastructure
- Monitoring
- JRA3 introduction

GÉANT2: Hybrid infrastructure



Connect. Communicate. Collaborate

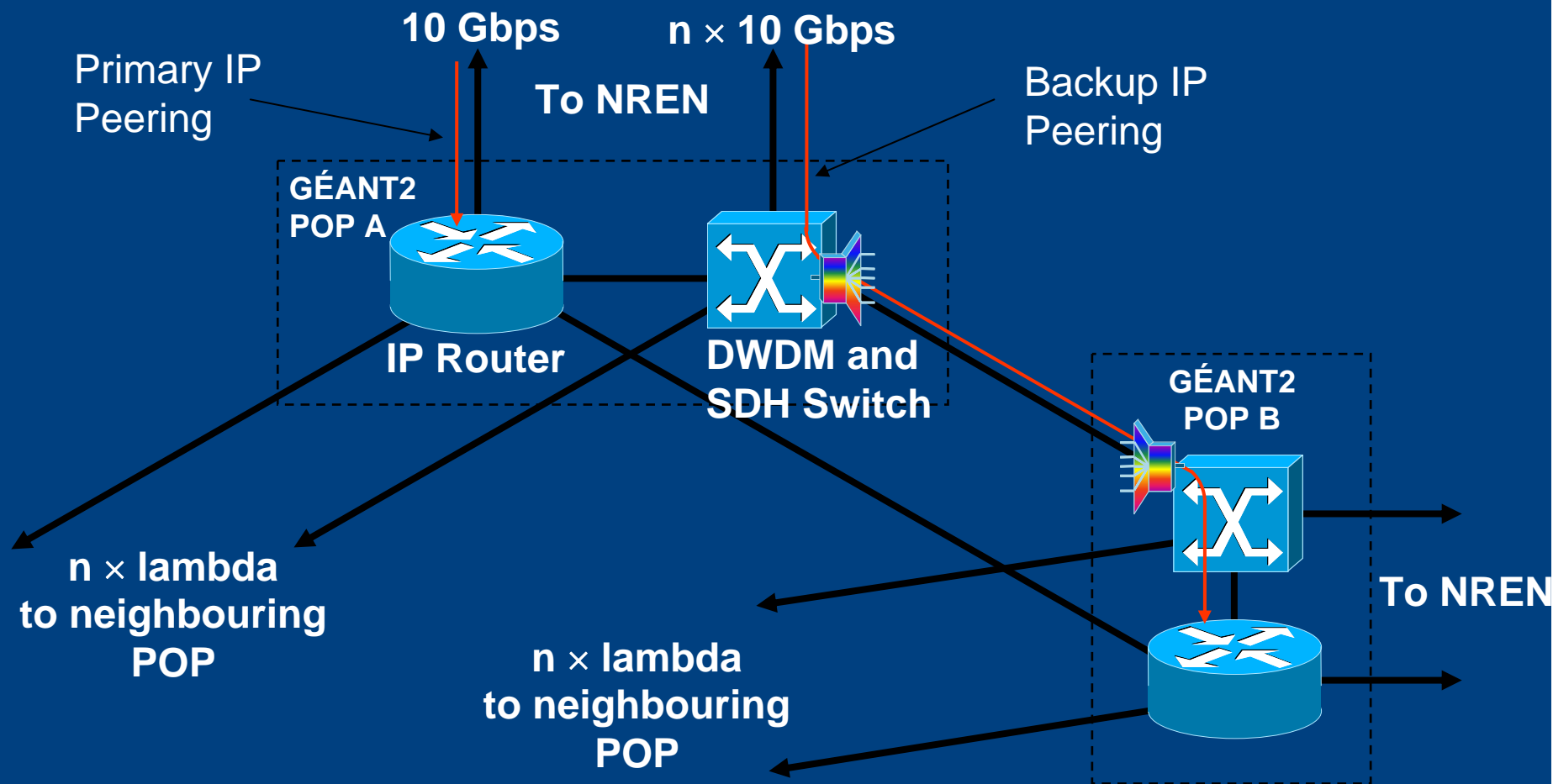



Services over GÉANT2

Point-to-point GE (10GE access)

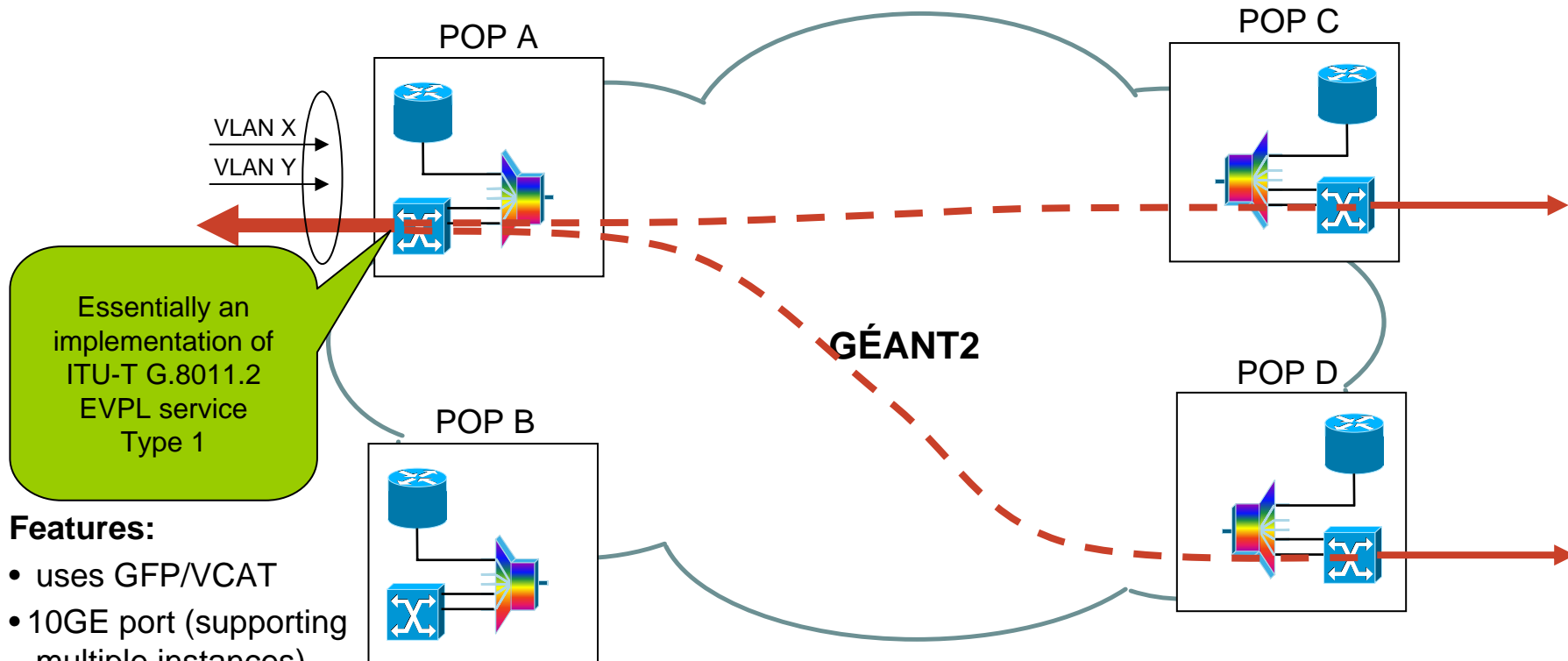

Features:

- uses GFP/VCAT
- 10GE port (supporting multiple instances)
- use 802.1Q VLAN tags as IDs
- sub (or >) 1G possible

Agenda



Connect. Communicate. Collaborate

- GEANT2 status and developments
- End to end services and the hybrid infrastructure
- Monitoring
- JRA3 introduction



Connect. Communicate. Collaborate

Problem space

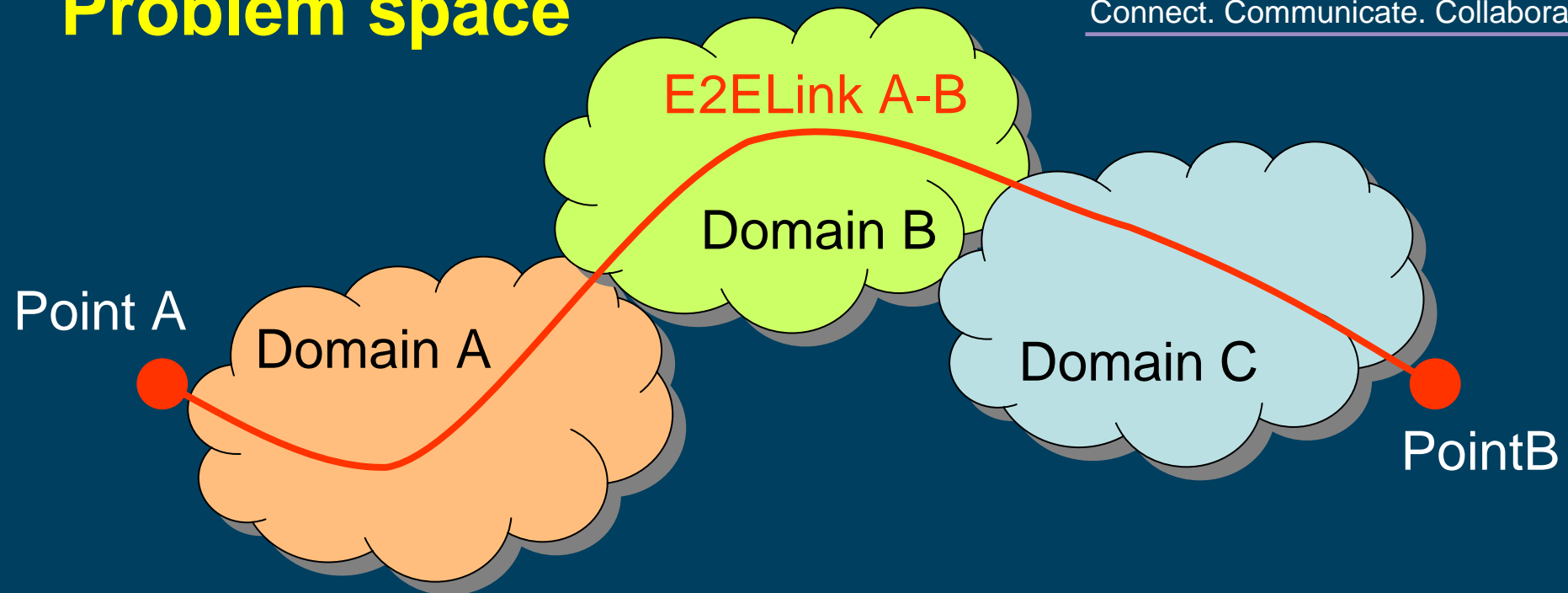

Goal: (near) real-time monitoring (link status) of constituent DomainLinks (and links between domains) and whole end-to-end Link A-B.

The following applies to the GÉANT2+ service and the cross border fibres.



Divide & conquer

(JRA4 E2Emon info model)

Connect. Communicate. Collaborate

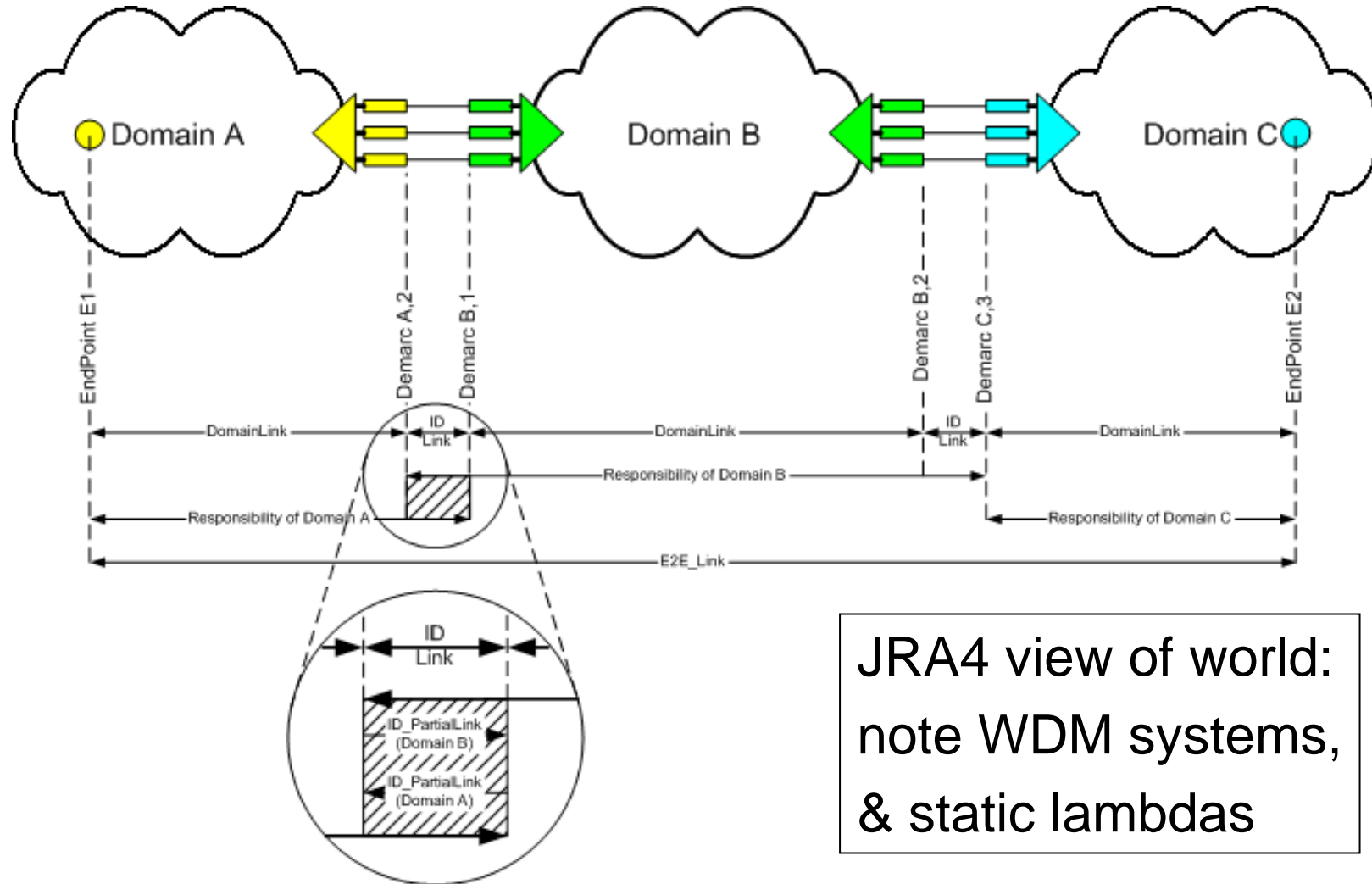

JRA4 view of world:
note WDM systems,
& static lambdas

Approach



Connect. Communicate. Collaborate

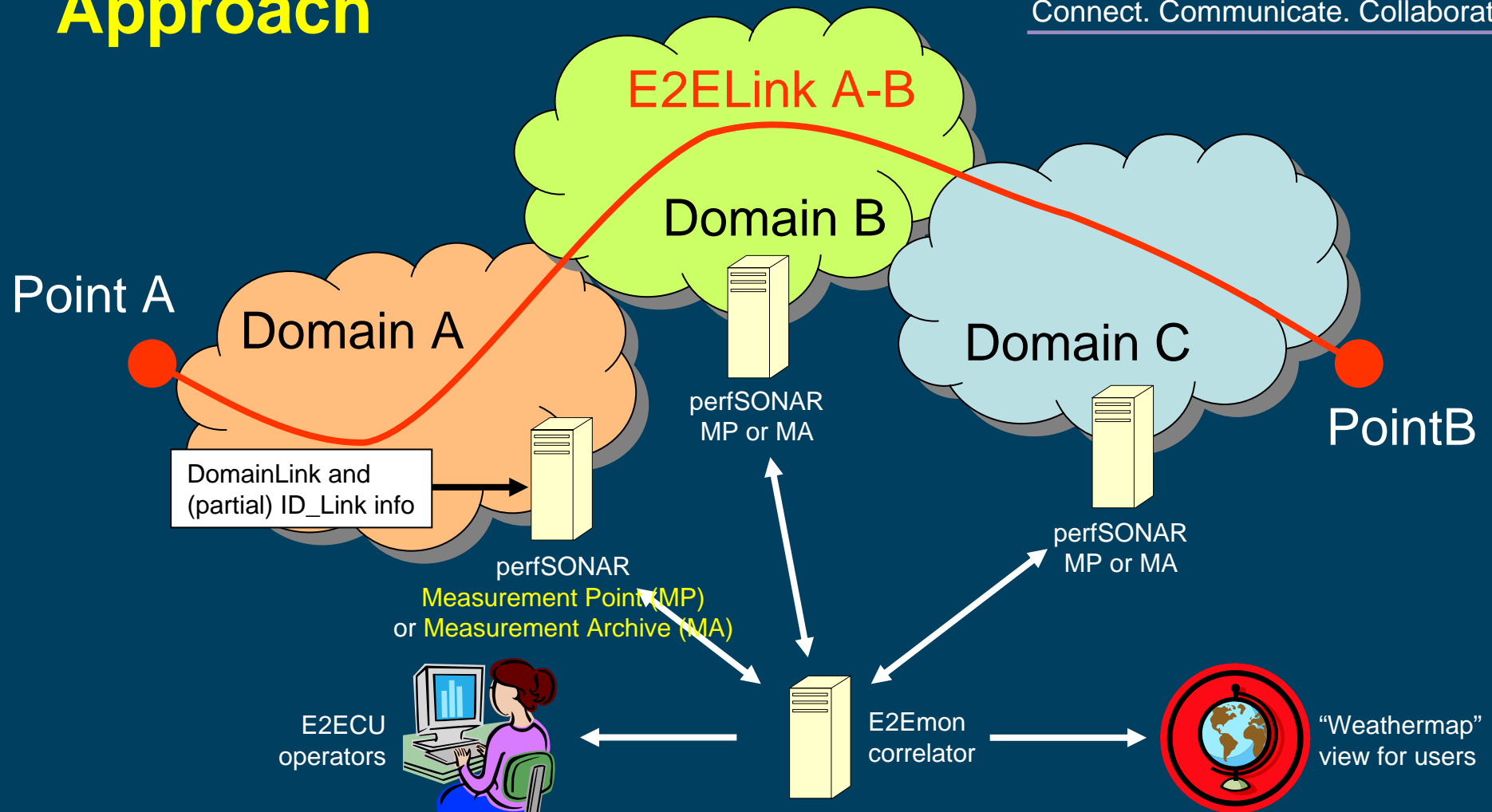



Connect. Communicate. Collaborate

LHC-OPN e2e Monitoring

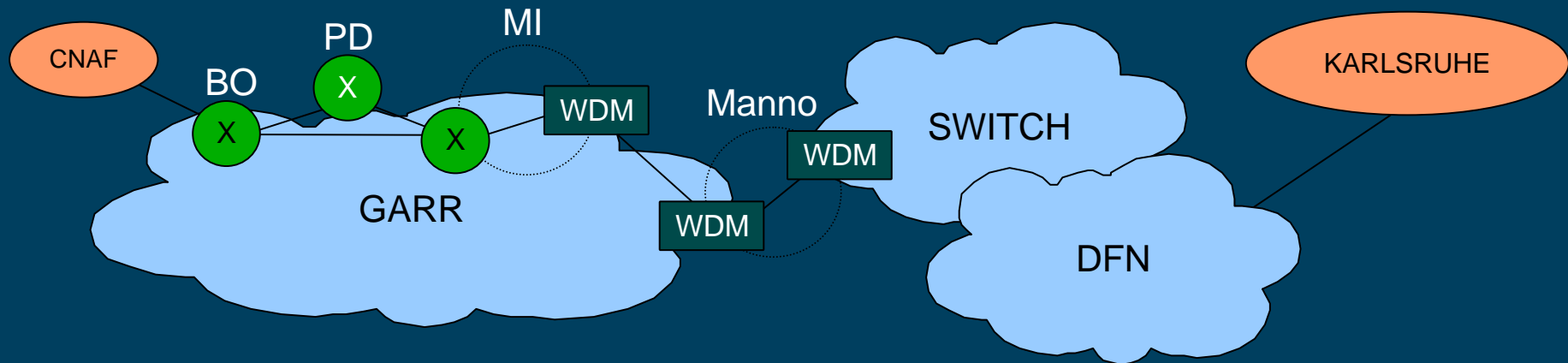

- **e2e lightpath**
from CNAF (Bologna, Italy) to Karlsruhe (Germany)
- The logical topology built for the e2e monitoring system abstracts the internal topology of each domain and produces a simpler topology.



Connect. Communicate. Collaborate

LHC-OPN e2e Monitoring

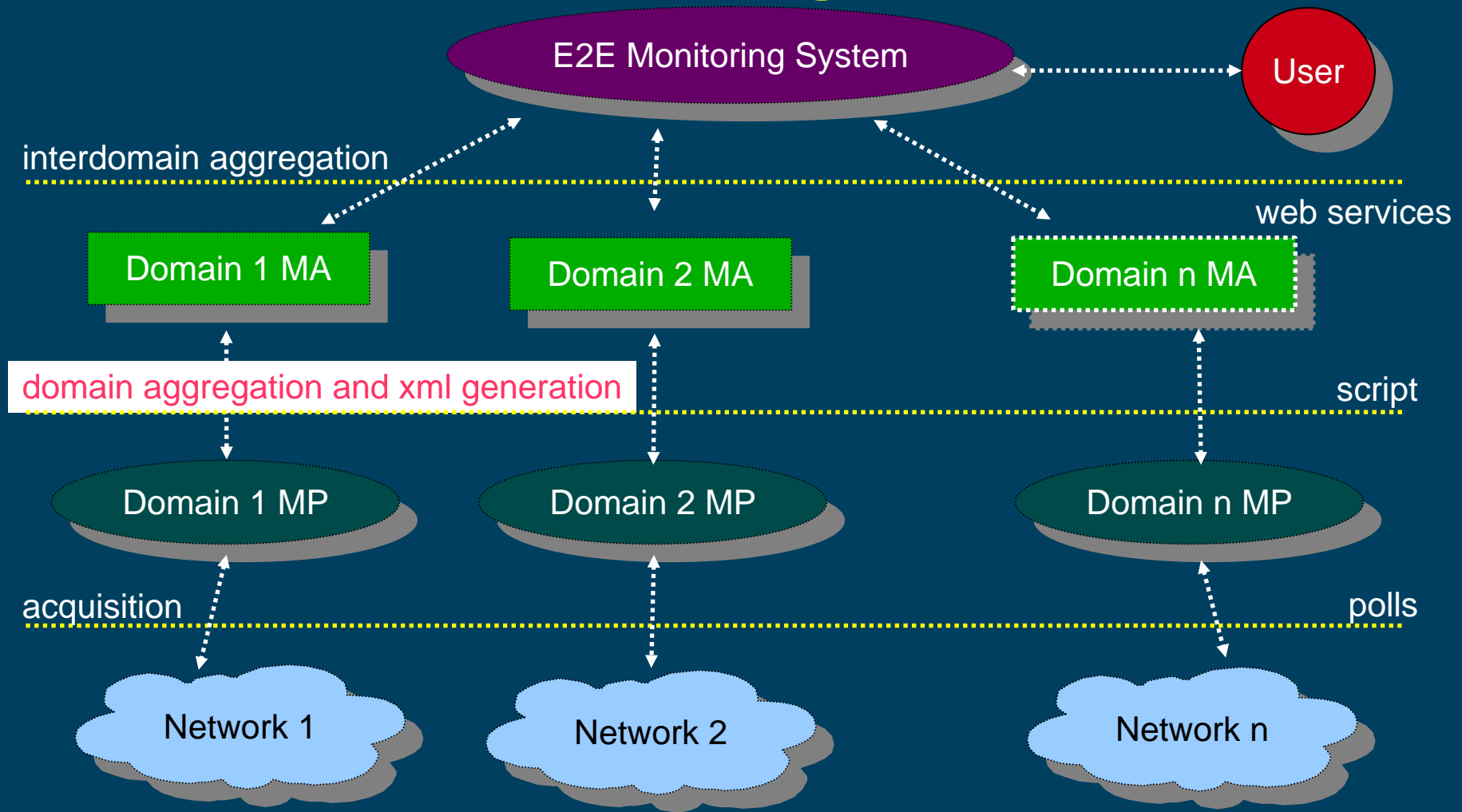

CNAF - CERN E2E MS user interface

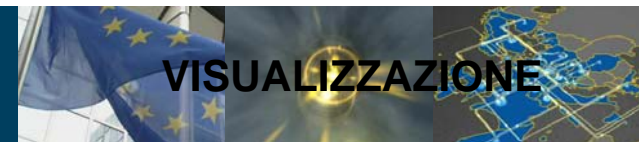

Connect. Communicate. Collaborate

[Start page](#)

E2ECU view

[All E2E Links](#)
[Problem Links](#)

Domain/NREN view

[GEANT2](#)
[SWITCH](#)
[GARR](#)

Project view

[LHCOPN](#)

Monitored Links for Domain GARR

E2E Link ID	Topology Point A	Role	Topology Point B	Role	(Domain) Local Name	Link Type	Oper. Status	Admin. Status	Time Stamp
CERN-CNAF-LHCOPN-001	GARR-CNAF	E	GARR-MIL	D	CNAF-MILAN	Domain	Up	Normal Oper.	1157103952
CERN-CNAF-LHCOPN-001	GARR-MIL	D	GEANT2-MIL	D	(GARR) MILAN-GEANT2 (GEANT2) GEANT2-IT-CERN-CNAF	ID Part.Info	Up	Normal Oper.	1157103952 2006-08-24T13:53:02.0+0100
CNAF-GRIDKA-LHCOPN-001	GARR-CNAF	E	GARR-MAN	D	CNAF-MAN	Domain	Up	Normal Oper.	1157103952
CNAF-GRIDKA-LHCOPN-001	GARR-MAN	D	SWITCH-MAN	D	(GARR) GARR-SWITCH (SWITCH) mMA13-c4	ID Part.Info	Up (?)	Normal Oper. (?)	1157103952 2006-09-01T11:42:37+02:00

http://cnmdev.lrz-muenchen.de/e2e/lhc/G2_E2E_index.html (beta)

Agenda



Connect. Communicate. Collaborate

- GEANT2 status and developments
- End to end services and the hybrid infrastructure
- Monitoring
- JRA3 introduction



Connect. Communicate. Collaborate

The JRA3 Activity of GN2

- JRA3 is investigating the provision of 'Bandwidth on Demand' services to the NREN community
- The goal implies an environment that is:
 - Multi-domain
 - Using multiple transmission technologies
 - SDH, GFP over SDH, L2 MPLS VPN, Ethernet
- Requirements for:
 - end-to-end delivery of a non-contended capacity
 - a standardized interface for service requests at end-points
 - service level indication to end-users
 - advance reservation (scheduled)
 - modular and technology independent implementation

JRA3 architecture



Connect. Communicate. Collaborate

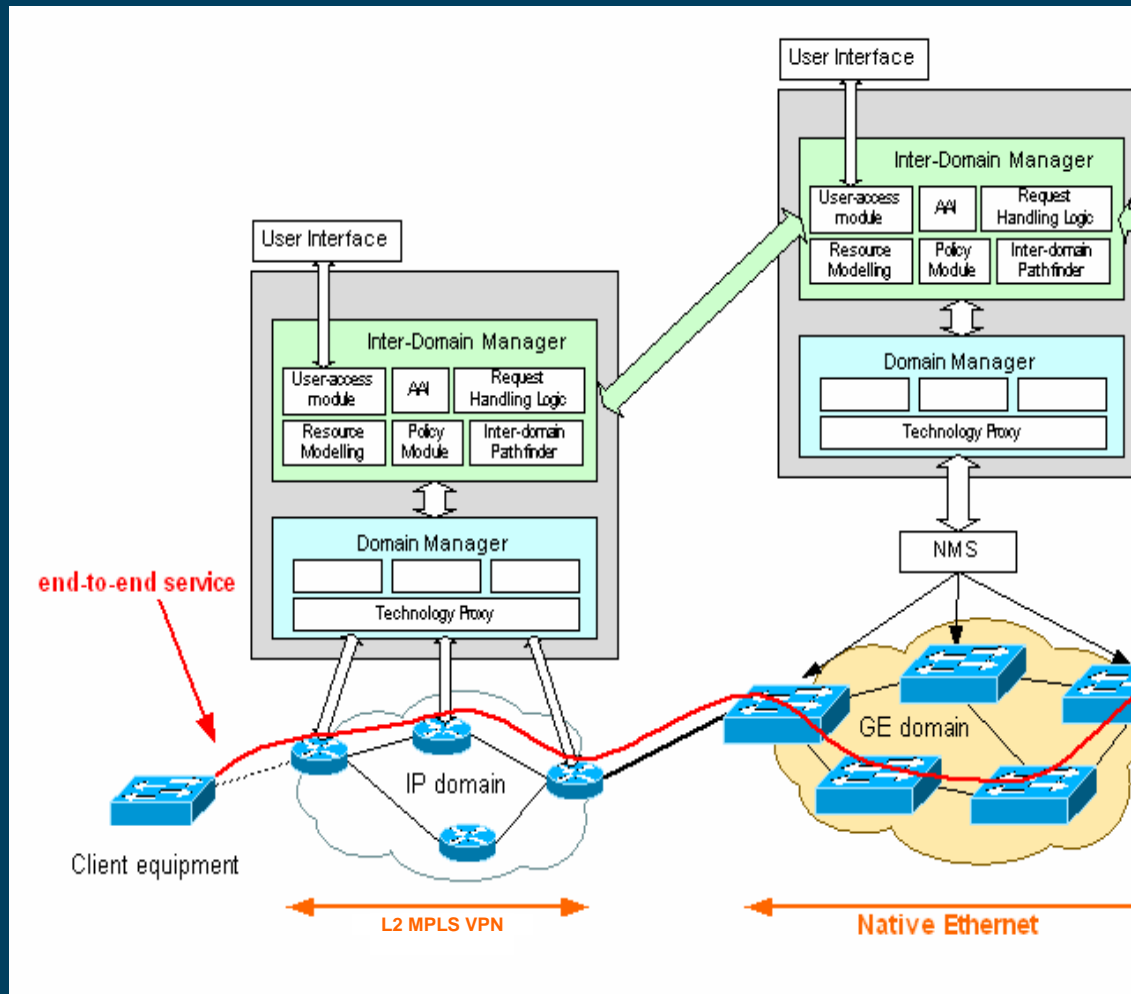

Key elements:

- Inter-Domain manager (IDM)
- Domain manager (DM)
- Resource modeling (aka Abstract representation)
- Path finder
- Technology proxies
- Standardized interfaces

Each domain participating in the BoD service provisioning needs to operate an IDM and honor the IDM-DM and IDM-IDM interfaces.

The local DM can be any technology, just a proxy is needed towards the IDM

JRA3

Distributed approach



Connect. Communicate. Collaborate

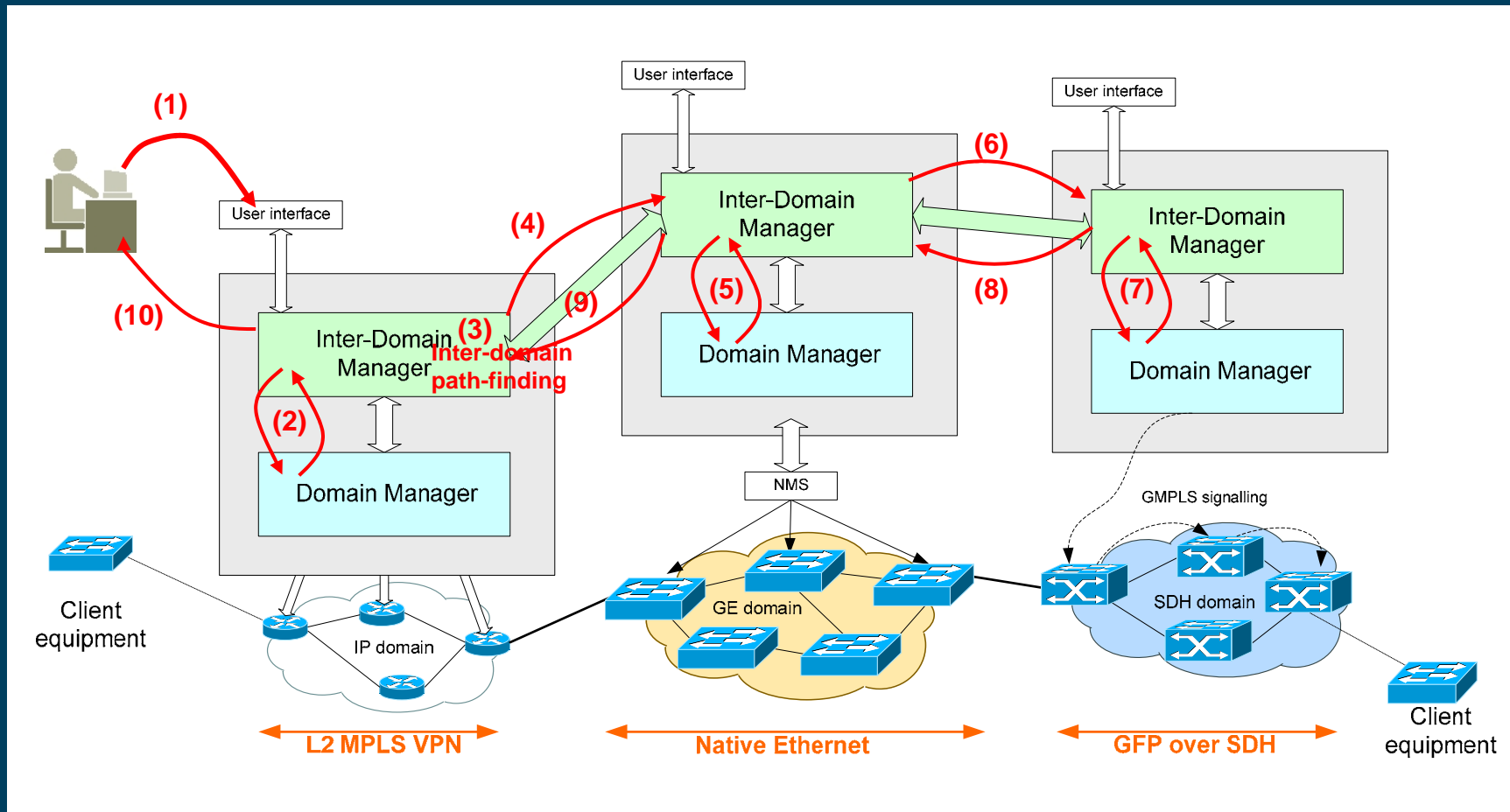

JRA3 Inter Domain Manager



Connect. Communicate. Collaborate

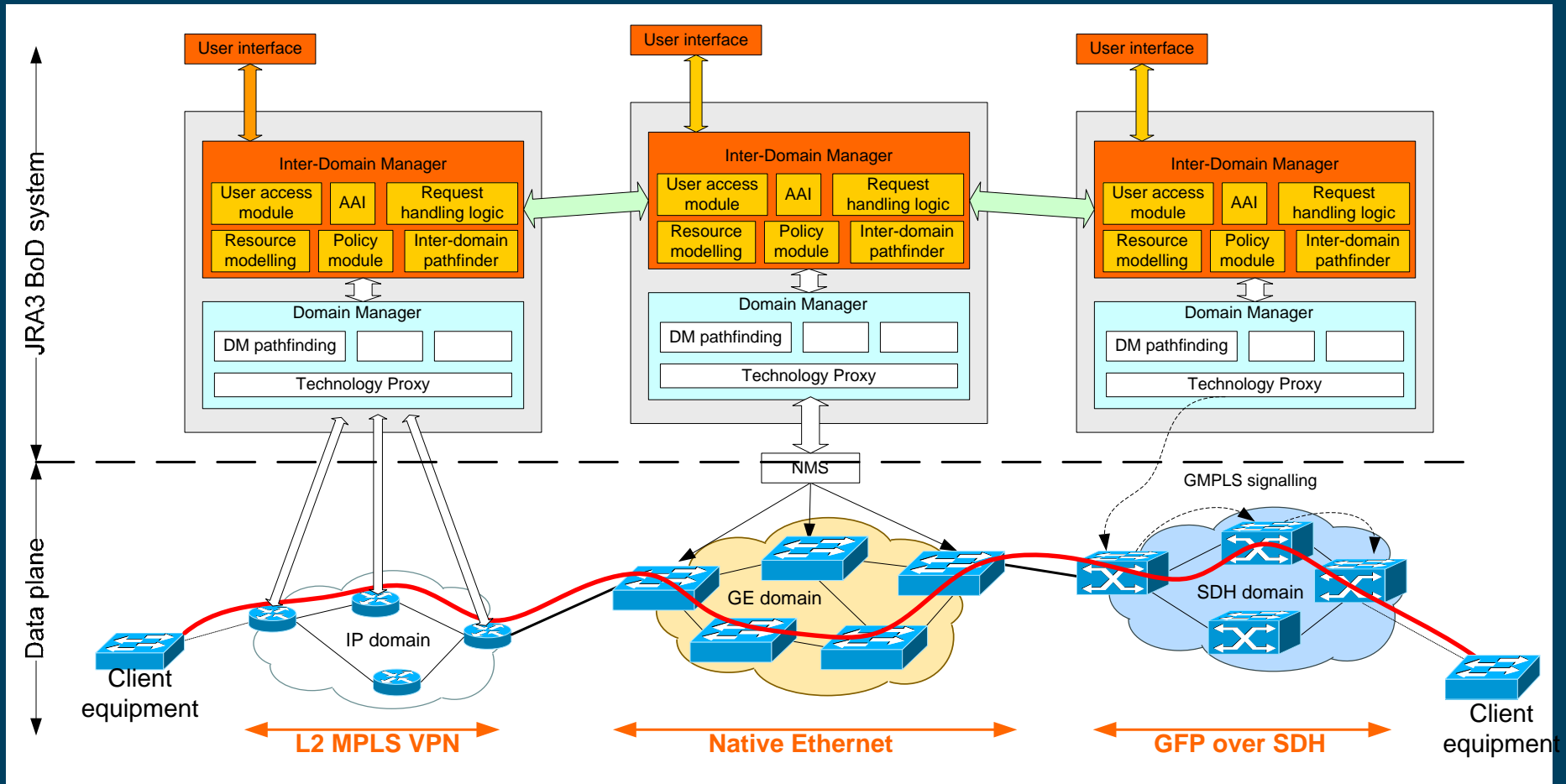

JRA3: IDM multi-domain issues



Connect. Communicate. Collaborate

The IDM faces a number of requirements and corresponding challenges related to its multi-domain scope:

- domain independence for resource usage policies and technological choices
- a **service and network abstraction schema (language/notation)** to describe very different networks, with different policies
 - a schema to allow a clear specification of the service
 - a network abstraction which allows inter-domain information exchange independently of the underlying technologies
- **stitching of multi technology domains**
- **multi-domain path finding procedure**
- advance reservation
- monitoring
- Authentication and Authorization

JRA3: Current status



Connect. Communicate. Collaborate

- Framework and Architecture defined
- IDM functional specification released
- IDM phase 0 (simplified in some modules) implementation and testing done
- Draft abstract notation available
- Working on Pathfinding module , IDM phase 1 and abstract representation



Connect. Communicate. Collaborate

Thank you

JRA3: Pathfinding



Connect. Communicate. Collaborate

INTERDOMAIN:

- Currently OSPF(-TE) v4 + Opaque LSA (Quagga) + IPv6 Labels + IPv6 compatible addresses for routing propagation (**next** avoid QUAGGA and full IPv6 compatibility, OSPF)
- Minimization on delay with Dijkstra algorithm (**next**: multi constraint CSPF)
- Domain abstraction as pointlike structures (**next**: internal, simplified/abstracted, structure announcement)
- Topology pruning before path finding (based on time invariant and not on time variant parameters)



Connect. Communicate. Collaborate

JRA3: Policies and AAI

- “cost” model to be worked on. Cost can be “credits” assigned to users/groups and fare can be a function of capacity, time, RTT.
- AAI will start with a simple SSL based internal communications to be hooked to the GIdP and later to the eduGAIN infrastructure

JRA3

Why an Inter-Domain Manager



Connect. Communicate. Collaborate

- The effort to provision end-to-end Bandwidth on Demand services in the European scenario requires specific developments in inter-domain collaboration
- Splitting intra-domain management functionalities from inter-domain ones in separate modules, allows multi-domain R&D to proceed autonomously and focus on this less standardized area
- At the same time, it allows to leverage existing inter-domain managers through wrappers/proxies and interfaces, exploiting a modular approach
- This effort can provide solid experience for brokering services other than Bandwidth on Demand

JRA3

Domain independence



Connect. Communicate. Collaborate

- Collaborative and distributed effort through newly defined interfaces which extend the NNI standards
- No centralised management
- Better resilience
- A common naming and addressing schema for a large amount of devices
- An abstract network representation to ensure faithful service description
- Possibility to hide domain internals
- Clear separation of control and data plane also at the physical level when needed